

A large crowd of people is gathered for a parade. In the foreground, soldiers in dark uniforms with white gaiters are marching in formation on a paved street. The background is filled with a dense crowd of spectators. A tall, white monument or structure is visible in the distance.

INDIGENISATION NEEDS & CHALLENGES
BY
DIRECTORATE OF INDIGENISATION
(ARMY)

AIM

To
Give insight into a
comprehensive plan to
synchronize latest
development of Engineering
with actual requirements of
industries to assist in
Capability Building

PREVIEW

TECHNOLOGY PROLIFERATION

DOI : ROLE , ORGANISATION

INDIGENISATION PROCESS

SUCCESS STORIES VS CRITICAL TECH

CHALLENGES & WAY FORWARD

UPCOMING PROJECTS

INDUSTRY PARTICIPATION

CONCLUSION

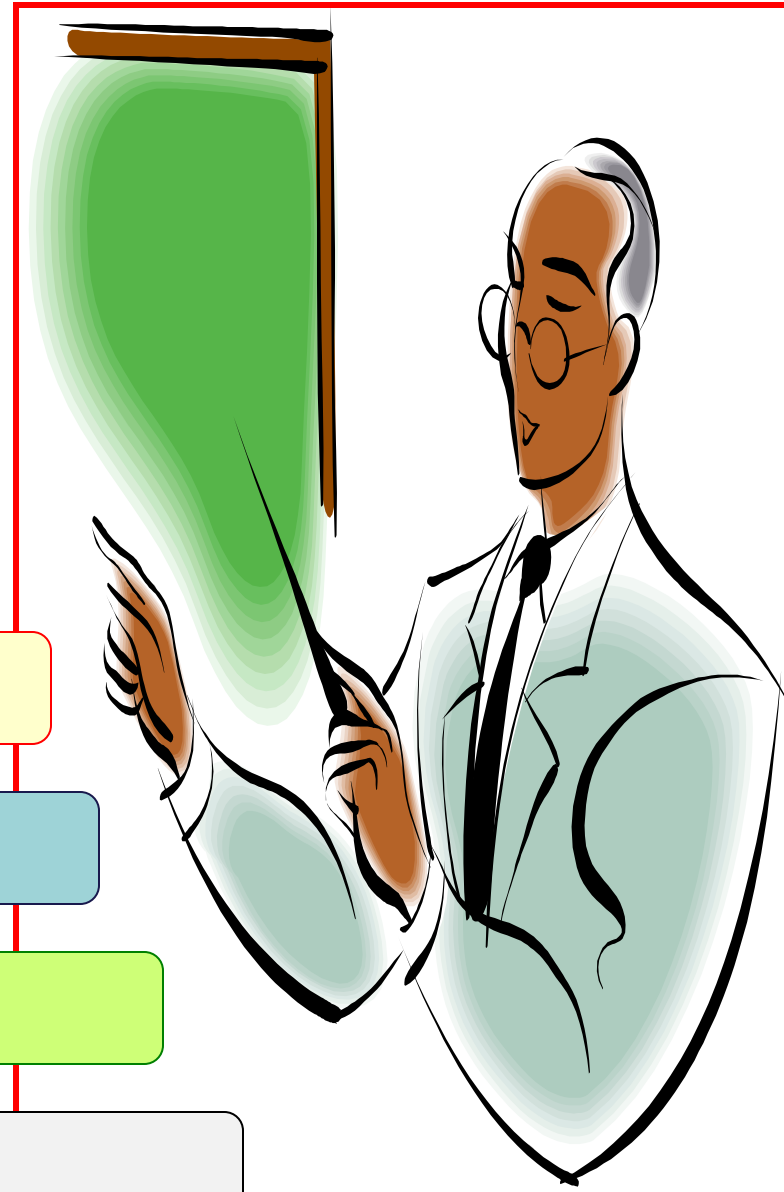

STAKE HOLDERS

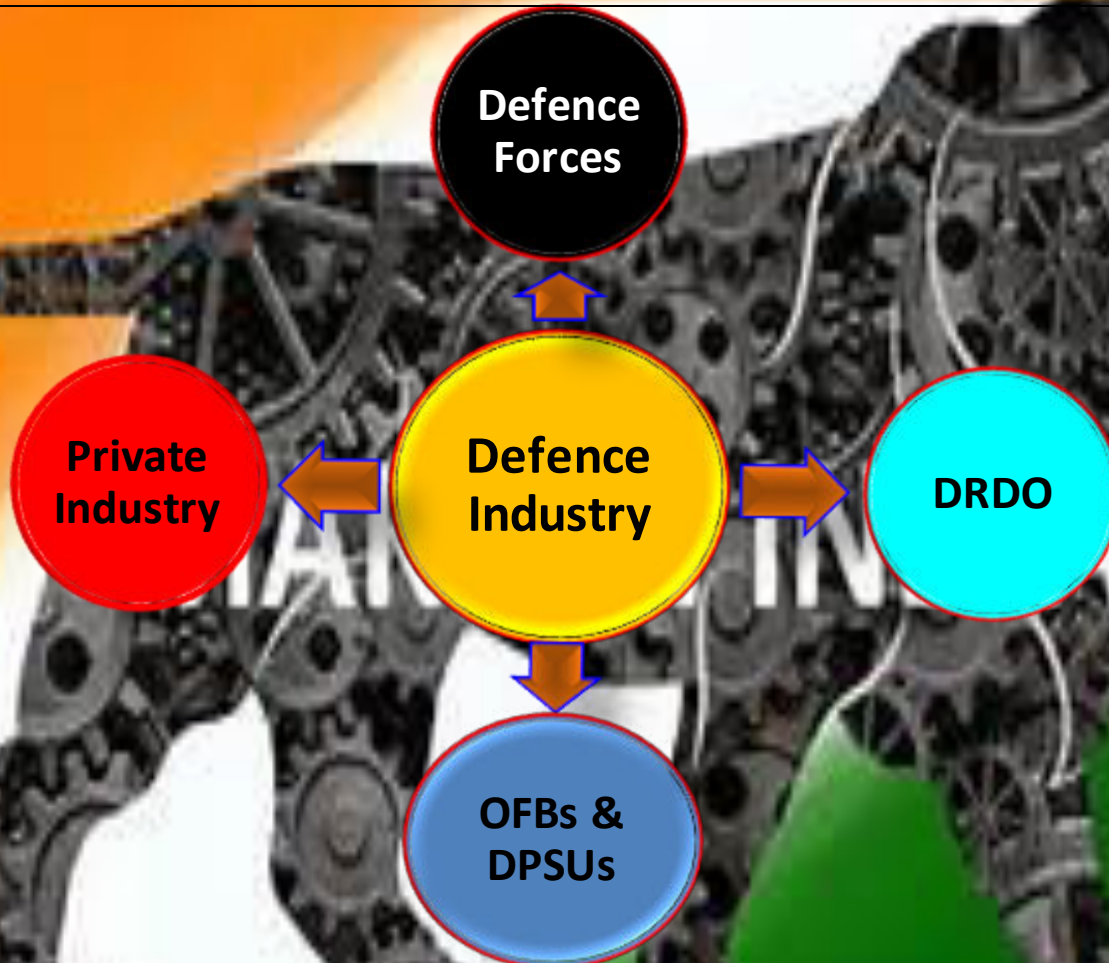

Capability Enhancement : Design & Build

DIRECTORATE OF INDIGENISATION (ARMY)

- **To build a strong and reliable indigenous defence production base for manufacture of spare parts / assemblies / sub-assemblies/ systems/ sub systems of imported equipment which are not being indigenised by Ordnance Factory Board /Defence Public Sector Undertakings**
- **Nodal point in the Integrated Headquarters of MoD (Army) for indigenisation of spare parts/ assemblies / sub-assemblies**

ROLE

- To carry out indigenisation of imported stores pertaining to the following disciplines:-
 - ✓ **Vehicle Stores**
 - ✓ **Electrical & Electronic Stores**
 - ✓ **Armament Stores**
 - ✓ **Engineer Equipment Stores**

ORGANISATIONAL STRUCTURE

DOI

**Indigenisation
Committee
(Vehicle)**

**Indigenisation
Committee
(Armament)**

**Indigenisation
Committee
(Electronics)**

**Indigenisation
Committee
(Engineering
Equipment)**

**Drawing &
Specification Wing
(Vehicle)
Pune**

**Drawing &
Specification Wing
(Armament)
Jabalpur**

**Drawing &
Specification Wing
(Electronics)
Bangalore**

**Drawing &
Specification Wing
(Engineering
Equipment)
Pune**

INDIGENISATION PROCESS

➤ Governed by Chapter 15 of DPM 2009

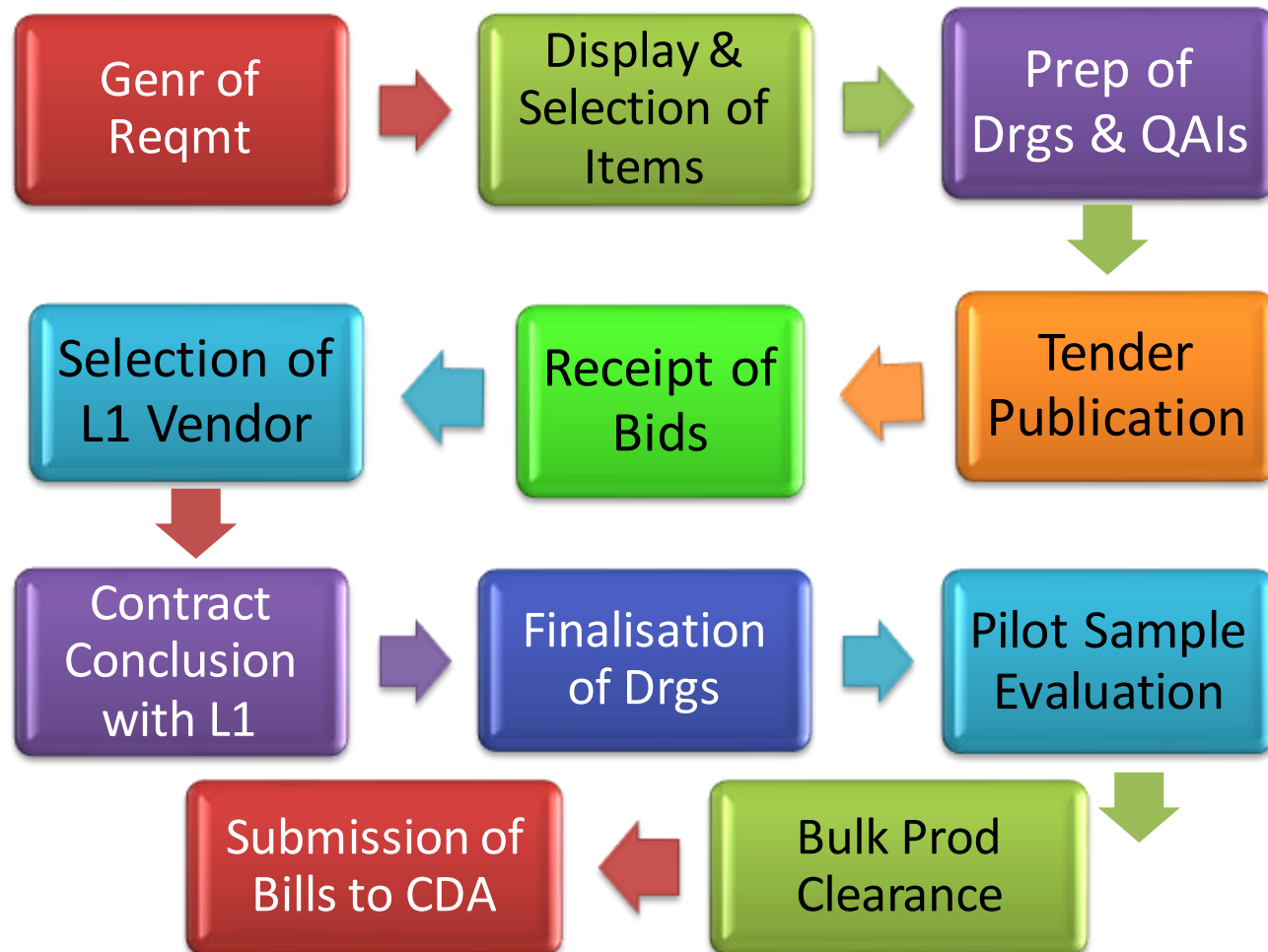

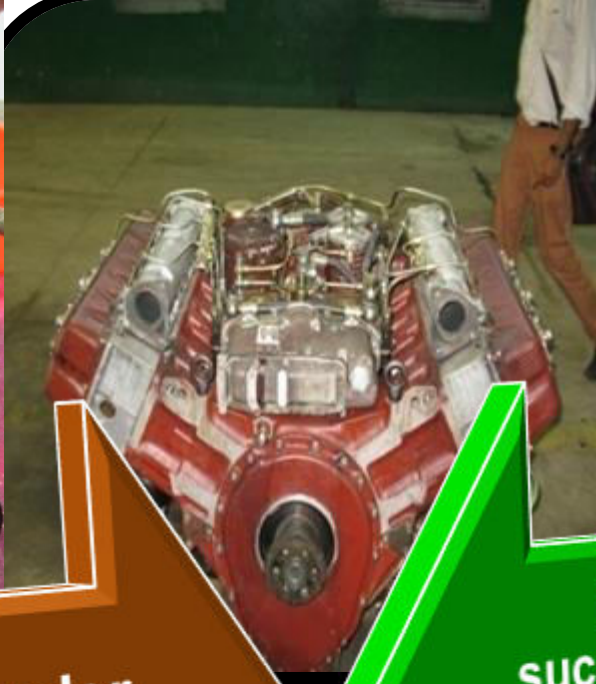

Items under
Indigenisation :
2886

Items
successfully
Indigenised :
570

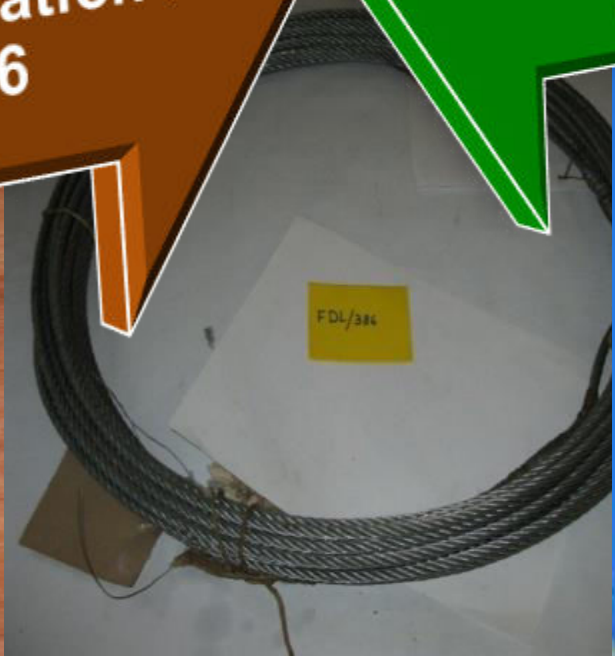

PLATFORM WISE INDIGENISATION

Platform	% of Items under Indigenisation
ARMAMENT	48.89%
AIR DEFENCE WEAPON SYSTEM	15.87%
SPECIAL VEHICLE	14.68%
'A' VEHICLE	10.18%
SMALL ARMS	8.43%
ARMOURED RECOVERY VEHICLE	1.95%

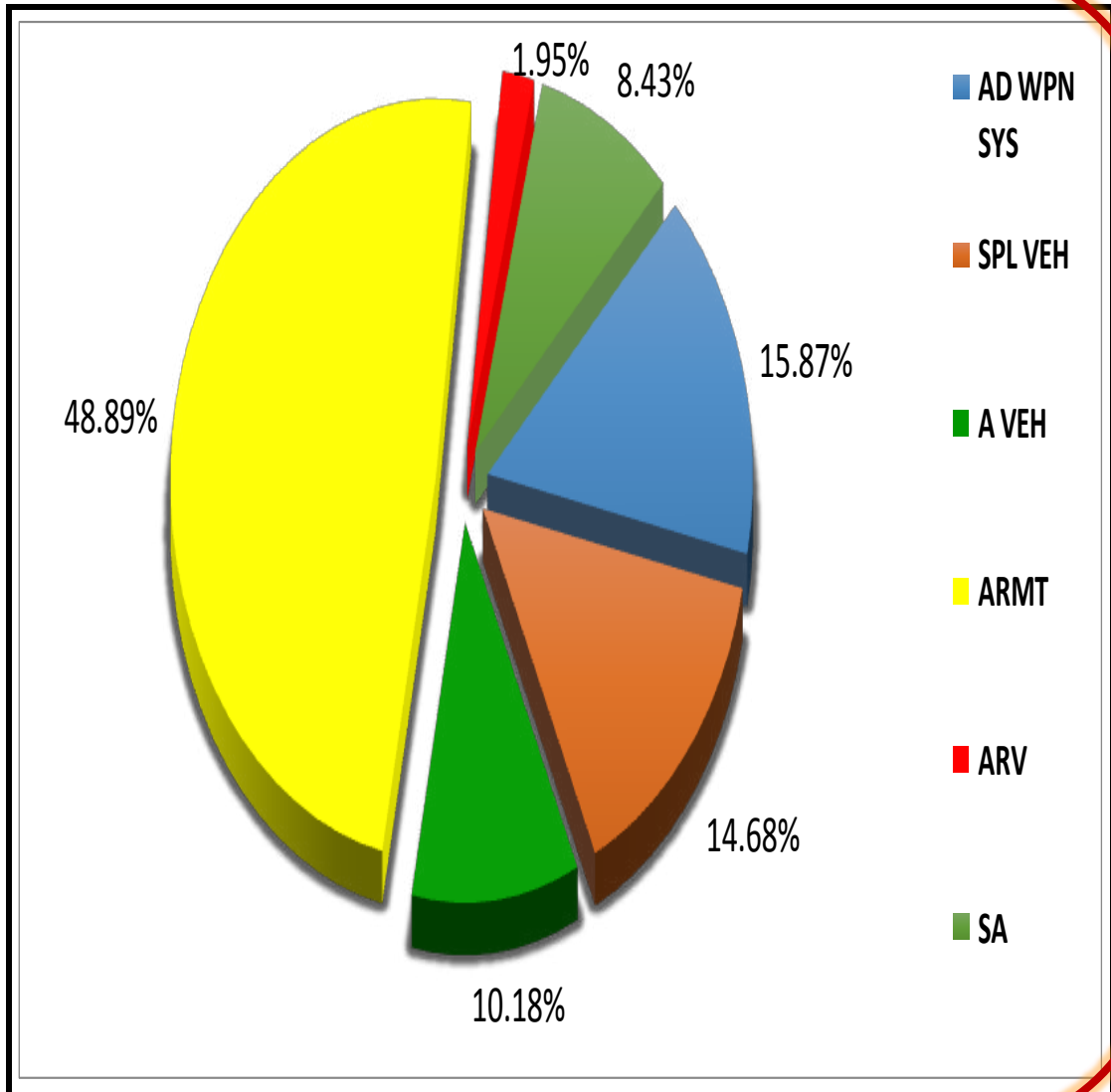

SUCCESS STORIES VS CRITICAL TECHNOLOGIES



Material



Engines

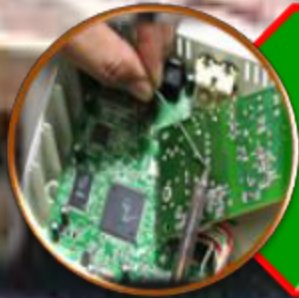

Electronics

A person in a dark uniform, possibly a pilot or astronaut, is holding a glowing blue globe. The globe is surrounded by a satellite and various data overlays, including a map and a grid. The background is dark, and the overall scene suggests a high-tech or space-related environment.

MATERIAL TECHNOLOGY

TRACK ASSEMBLY : STRELLA 10M

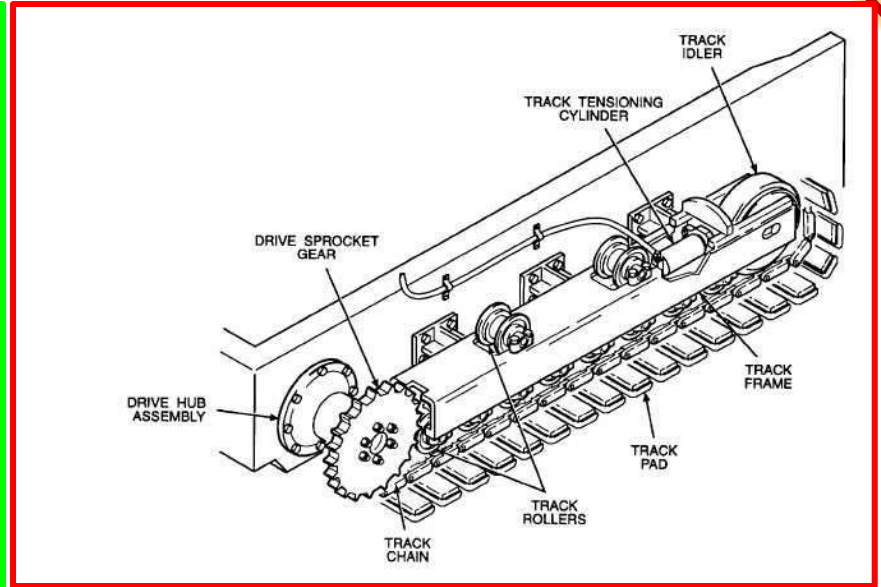

Brief description: Track assembly mounted on road wheel. Drive from sprocket for easy rolling

- **Low Population & Imported**
- **Production line closed**
- **Developed through Indian Vendor**

Metallurgical & Technical expertise achieved Indigenously

TRACK ASSEMBLY : TANK T-90

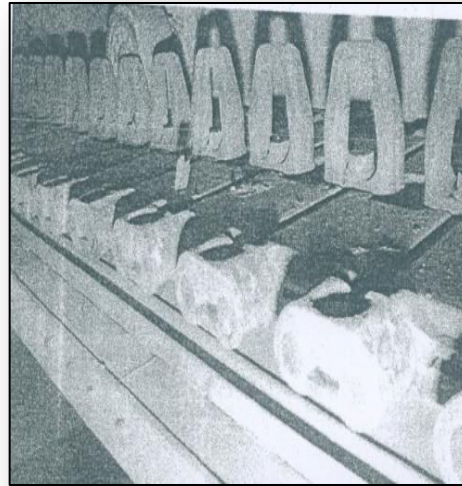

Brief description: Track assembly mounted on road wheel. Drive from sprocket for easy rolling

- **Extensively exploited leading to frequent breakdown**
- **Import dependence not cost effective**

Self – Reliance & Forging capability enhanced

TRACK ASSEMBLY : TUNGUSKA



Brief description: Track assembly mounted on road wheel. Drive from sprocket for easy rolling

- **Import origin, track not available due to production line closure**
- **Low Population equipment and sustenance difficult**

Sustenance of Low Population Equipment being addressed

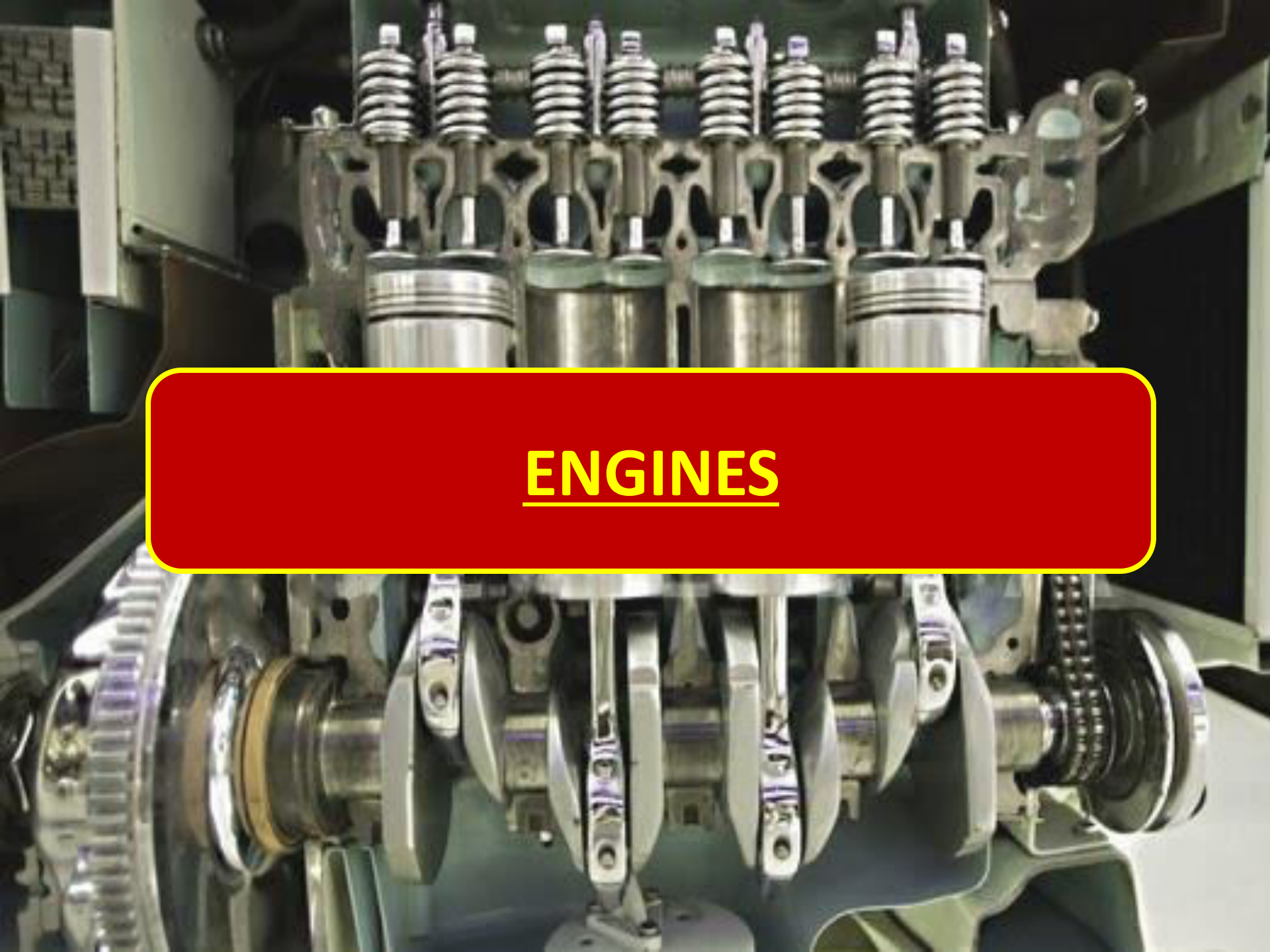

ENGINES

POWER PACK : INFANTRY COMBAT VEHICLE BMP - II



- **Need felt to upgrade BMP engine from 280 HP to 360 HP**
- **Change transmission from manual to auto**
- **Modular design**
- **Six vendors participating in trials**

Technology Upgrade with simultaneous Technology insertion

AUXILIARY POWER UNIT : BOFORS



Brief description: Auxiliary Power Unit for self propulsion

- Major import substitution @ 5 lakhs against 47 lakhs of imported engine

Major Import Substitution & Cost Saving

ARMoured RECOVERY VEHICLE : VT-72B



- **Vintage – 18 to 24 yrs and overdue for base overhaul**
- **OEM facility shut down leading to non availability of spares**
- **Case initiated for indigenisation of utility portion**

Platform based Indigenisation with 15 Years product support



ELECTRONICS

ARTILLERY METEOROLOGICAL SYSTEM RADIO SONDE



- Need felt to indigenise Arty Met Sys due to high cost of spares from OEM
- EoI for NCNC devp of Arty Met Sys uploaded in May 2018

Industries' keenness to participate even on NCNC basis

A green rectangular sign with rounded corners and a white border, mounted on two wooden posts. The sign features the word "Challenges" in a large, white, sans-serif font. The background is a bright blue sky with scattered white clouds. The sign is tilted slightly to the right.

Challenges

CHALLENGES

Obsolescence Mgt : Need for Technology Upgrade / Redesign

Long Gestation Period & Intricate Procurement Process

Foreclosure of SO due to non delivery

R&D – Timeline & Cost for complex Assembly / Sub-assembly

Uneconomical volumes

WAY FORWARD

Indigenisation to target newly inducted equipment

Indigenisation to focus on major assembly/sub-assembly

Indigenisation based on import list



UPCOMING PROJECTS

CRITICAL ASSEMBLY UNDER DEVELOPMENT

Nomenclature – Recoil Mechanism
Main Eqpt – 105/37MM IFG



Nomenclature – Compressor EU
Main Eqpt – BOFORS GUN

CRITICAL ASSEMBLY UNDER DEVELOPMENT

Nomenclature – Barrel/ Tube

Main Eqpt – 122MM Grad BM-21



Nomenclature – Castor Wheel Arm

Main Eqpt – BOFORS GUN

CRITICAL ASSEMBLY UNDER DEVELOPMENT

Nomenclature – Radiator

Main Eqpt – BOFORS GUN

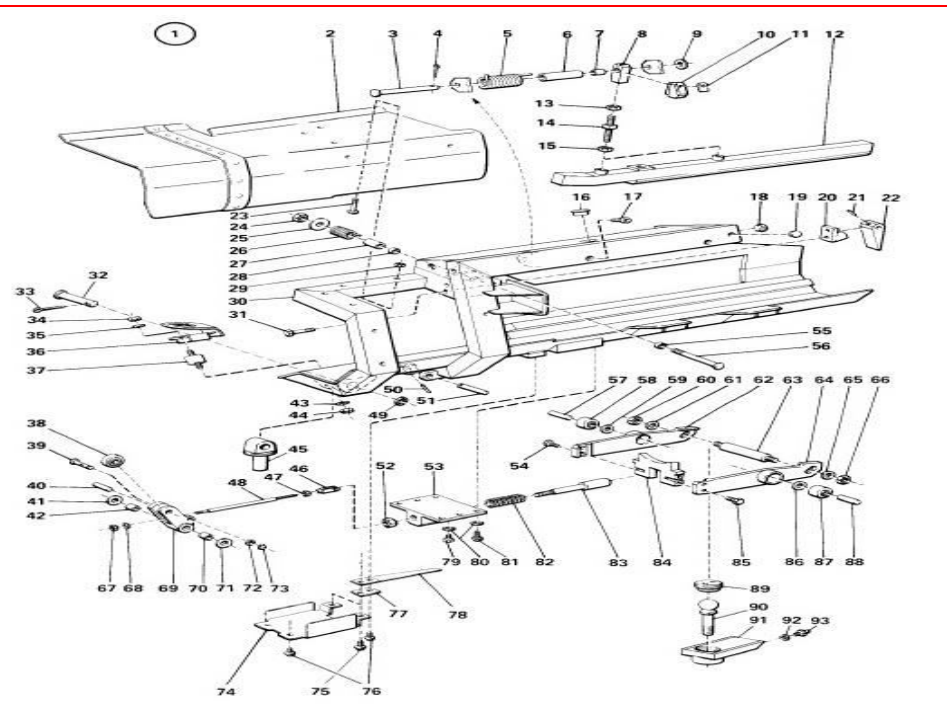

Nomenclature – Loading Tray

Main Eqpt – BOFORS GUN

CRITICAL ASSEMBLY UNDER DEVELOPMENT

Nomenclature – Rammer Unit

Main Eqpt – BOFORS GUN



Nomenclature – Loading Table

Main Eqpt – BOFORS GUN

CRITICAL ASSEMBLY UNDER DEVELOPMENT

Nomenclature – Elevating Cylinder
Main Eqpt – BOFORS GUN

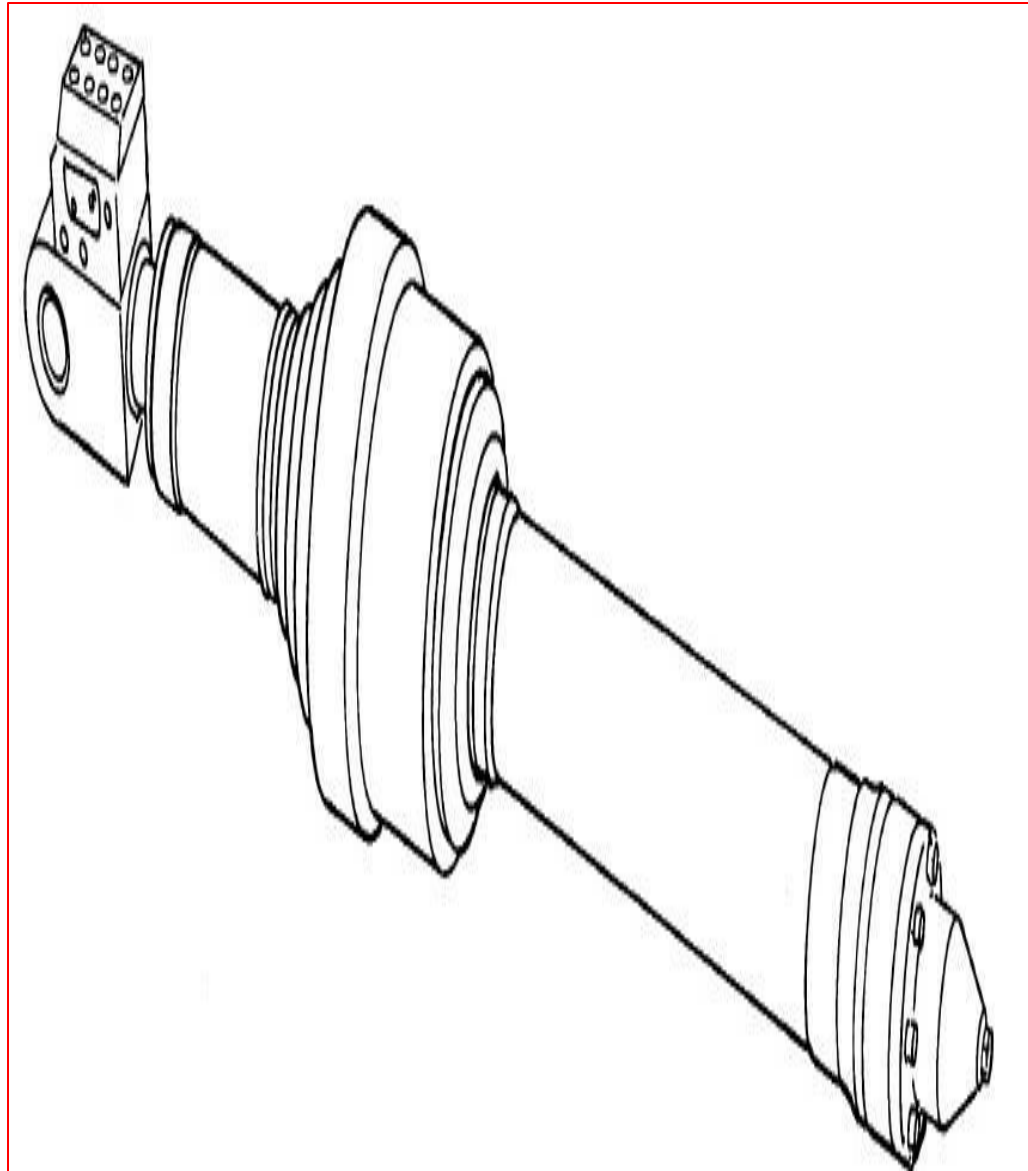



INDUSTRY PARTICIPATION

SCHEDULE OF INDIGENIZATION SUB COMMITTEE **MEETING : 2018**

Ser No	Venue	Equipment	Date : ISC meet
1	CAFVD, KIRKEE	T-72, T-90, ICV BMP , SPECIAL VEHICLES	DEC 2018
2	CASD DELHI CANTT	UAV SEARCHER MK-IA & MK- II & HERON	BEING PLANNED

HOW TO PARTICIPATE

- **Central Public Procurement Portal** (<https://eprocure.gov.in>)
 - ✓ Visit CPP Portal and search for DOI to locate all the active RFPs of DOI
 - ✓ All cases are dealt as e-procurement only

- **Link to DoI webpage**
 - ✓ <https://indianarmy.nic.in> Directorate/ Branches DOI
 - ✓ Shortcut (<http://goo.gl/tt2jyt>)

ACTIVE RFP ON WEB

7/4/2016

cppp - Google Search

Google

cppp

Sign in

cpp portal
cppp demo
cccp
cppp nic

About 2,74,000 results (0.26 seconds)

eProcurement System Government of India - Eprocure.gov.in

<https://eprocure.gov.in/eprocure/app>

Logo, Home, 01 Jul 2016, Search | Latest Active Tenders | Tenders by Closing Date | Corrigendum | Bid Awards | CPPP Home · Home · Contact Us · Sitemap ...

ePublishing System ...

ePublishing System ... ARM of Residential building civil work at ...

[More results from eprocure.gov.in »](#)

Downloads

S.No, Downloads, URL. 1, LibreOffice suite, <https://www...>

Certificate Program in Public Procurement (CPPP) | Public ...

www.procurementlearning.org/certificate-program-public-procurement-cppp/

World Bank offers an online training course to attain a Certificate Programme in Public Procurement (CPPP), free of cost.

Certificate Program in Public Procurement (CPPP) Launched in ...

www.procurementlearning.org/certificate-program-in-public-procurement-cppp-laun...

May 22, 2014 - The Certificate Program in Public Procurement (CPPP) was officially launched in

ACTIVE RFP ON WEB

7/4/2013

eProcurement System Government of India



04-Jul-2013

[Search](#) | [Latest Active Tenders](#) | [Tenders by Closing Date](#) | [Compendium](#) | [Bid Awards](#) | [CPPE Home](#)

[HOME](#)

[Contact Us](#)

[SEARCH](#)

* Additional Help Desk Numbers on publishing and procure, with effect from 04-May-2013 09:00 AM onwards

MIS Reports

[Tenders by Location](#)

[Tenders by Organisation](#)

[Tenders by Classification](#)

[Tenders in Archive](#)

[Tenders Status](#)

[Cancelled Tenders](#)

[Downloads](#)

[Announcements](#)

[Recognitions](#)

[Site compatibility](#)

GOVERNMENT OF INDIA
india.gov.in

MMP on
eProcurement

Advanced Tender Search

[Back](#)

Tender Type *	- Select -	Tender ID	<input type="text"/>
Organisation	- Select -	Tender Reference Number	<input type="text"/>
Department	- Select -	Work/Item Title	<input type="text"/>
Division	- Select -	Tender Category	- Select -
Sub Division	- Select -	Product Category	- Select -
Form of Contract	- Select -		
Pincode	<input type="text"/>		
Value Criteria	- Select -	- Select -	
Date Criteria	- Select -	From <input type="text"/>	To <input type="text"/>
		Clear	Search

ACTIVE RFP ON WEB

The screenshot displays the Government of India Central Public Procurement Portal (eProcurement) interface. The page header includes the Government of India logo, the date 13-Nov-2018, and navigation links for Search, Active Tenders, Tenders by Closing Date, Corrigendum, Bid Awards, CPPP Home, Home, and Contact Us. The main content area is titled "Advanced Tender Search" and features a search form with the following fields:

- Tender Type: Open Tender
- Organisation: IHQ of MoD (Army)-(OSCC)
- Department: MGO BR-IHQ of MoD (Army)-(O
- Division: DGEME-MGO BR-IHQ of MoD (A
- Sub Division: DOI-IHQ of MoD (Army)-(OSCC
- Form of Contract: -Select-
- Pincode: [Empty]
- Value Criteria: -Select-
- Date Criteria: -Select-
- Tender ID: [Empty]
- Tender Reference Number: [Empty]
- Work/Item Title: [Empty]
- Tender Category: -Select-
- Product Category: -Select-

Below the search form, there is a Captcha field with the text "Enter Captcha" and a Captcha image showing the characters "X J 5 6 B U". To the right of the Captcha is a "Refresh" button. At the bottom right, there are "Clear" and "Search" buttons. The left sidebar contains navigation options: MIS Reports, Tenders by Location, Tenders by Organisation, Tenders by Classification, Tenders in Archive, Tenders Status, Cancelled/Retendered, Downloads, Announcements, Recognitions, and Site compatibility.

ACTIVE RFP ON WEB

Government of India
Central Public Procurement Portal
(eProcurement)

13-Nov-2018 Search | Active Tenders | Tenders by Closing Date | Corrigendum | Bid Awards | CPPP Home Home | Contact Us | SiteMap

< Additional Help Desk Number

MIS Reports

Tenders by Location

Tenders by Organisation

Tenders by Classification

Tenders in Archive

Tenders Status

Cancelled/Retendered

Downloads

Announcements

Recognitions

Site compatibility

Welcome to eProcurement System
The eProcurement System of India enables the Tenderers to download the Tender Schedule free of cost and then submit the bids online through this portal.

CPPP Dashboard GET IT ON Google Play Download on the App Store

Latest Tenders

Tender Title	Reference No	Closing Date	Bid Opening Date
AT KOTLA FIROZSHAH DELHI			
5. IISER-K/PurEnq/523/G/DPS/18-19	IISER-K/PurEnq/523/G/DPS/18-19	27-Nov-2018 02:00 PM	28-Nov-2018 02:00 PM
6. Fabrication of Stainless Steel Casualty Evacuation	ENQ/127/INMAS/18-19	12-Dec-2018 12:00 PM	13-Dec-2018 12:00 PM
7. Medical Stores	7019/DAO/CP/IFA/2018-19/20	27-Nov-2018 10:45 AM	27-Nov-2018 11:00 AM

Latest Tenders updates every 15 mins. More...

Latest Corrigendums

Corrigendum Title	Reference No	Closing Date	Bid Opening Date
5. Extension of TOD	AR/MMP/220/1000038664/171215	22-Nov-2018 03:00 PM	24-Nov-2018 03:00 PM
6. Due date extended	CMRL/S T/IT/02/2018	27-Nov-2018 03:00 PM	28-Nov-2018 03:00 PM
7. Extension of TOD	AR/MMP/219/300004839/F180090	22-Nov-2018 03:00 PM	23-Nov-2018 03:00 PM

User Login

Login ID *

5 E 2 U K T

Captcha *

Login

Online Bidder Enrollment
Generate / Forgot Password?
Find My Nodal Officer

Search with ID/Title/Reference no

Tender Search

 Go

Advanced Search

Help For Contractors

Information About DSC

FAQ

ADVANTAGES OF INDIGENISATION THROUGH DOI **FOR VENDORS**

- **Registration with DOI not mandatory. EMD not required if registered with any govt agency**
- **One time development cost paid in full to successful bidder**
- **Transparent bidding through on line e-proc portal. RFPs uploaded with photos, QAIs and Drgs**
- **All available drawing, sample, specification and know how shared free of cost**
- **Upgradation of technology and black box approach permissible**
- **Parallel development by two sources to ensure free flow**
- **EOQ is considered for indigenisation and commitment for subsequent orders from developed source**



CONCLUSION

CONCLUSION

- Attainment of Vibrant Defence Industry will ensure
 - **Strategic Independence**
 - **Sovereign Capability in selected areas**
 - **Cost Effective Defence Equipment**
 - **Collateral benefits ensuing from the endeavours of the defence industry**
- 



JAI HIND